

High Power Solid-State LED Light Source

LUSTRON X3

Introduction

For a brighter solid-state light source, **LUSTRON X3** is an energy-efficient building block generating enough light outputs suitable for most applications in lighting field. **LUSTRON X3** offers the best solid-state light source and you might realize your modern ideas of lightings.

LUSTRON X3 provides the best possible performance with life time longer than 30,000 hours*. With a nominal correlated color temperature of 2500~3100K for Warm White, 3250~4750K for Neutral White, and 4750~10000K for Cool White, similar to conventional indoor light source, **LUSTRON X3** is particularly designed for architects and commercial lighting designers.

*Note1: To optimize product performance and life time, constant DC at indicated forward current and T_b less than 60°C should be applied.

LUSTRON X3

LUSTROUS[®]

GREEN TECHNOLOGY OF LIGHTINGS

LUSTRON X3 Part Number Matrix

Table.1

Color	P/N
Warm White	LAS110CLC0D-SRFSD
Neutral White	LAS110MWC0D-SRFSD
Cool White	LAS110NWC0D-SRFSD

LUSTRON X3 Material

Chip Material	GaN Base
---------------	----------

LUSTRON X3 Chips Array

9 Chips Array

LUSTRON X3

Mechanical Dimensions

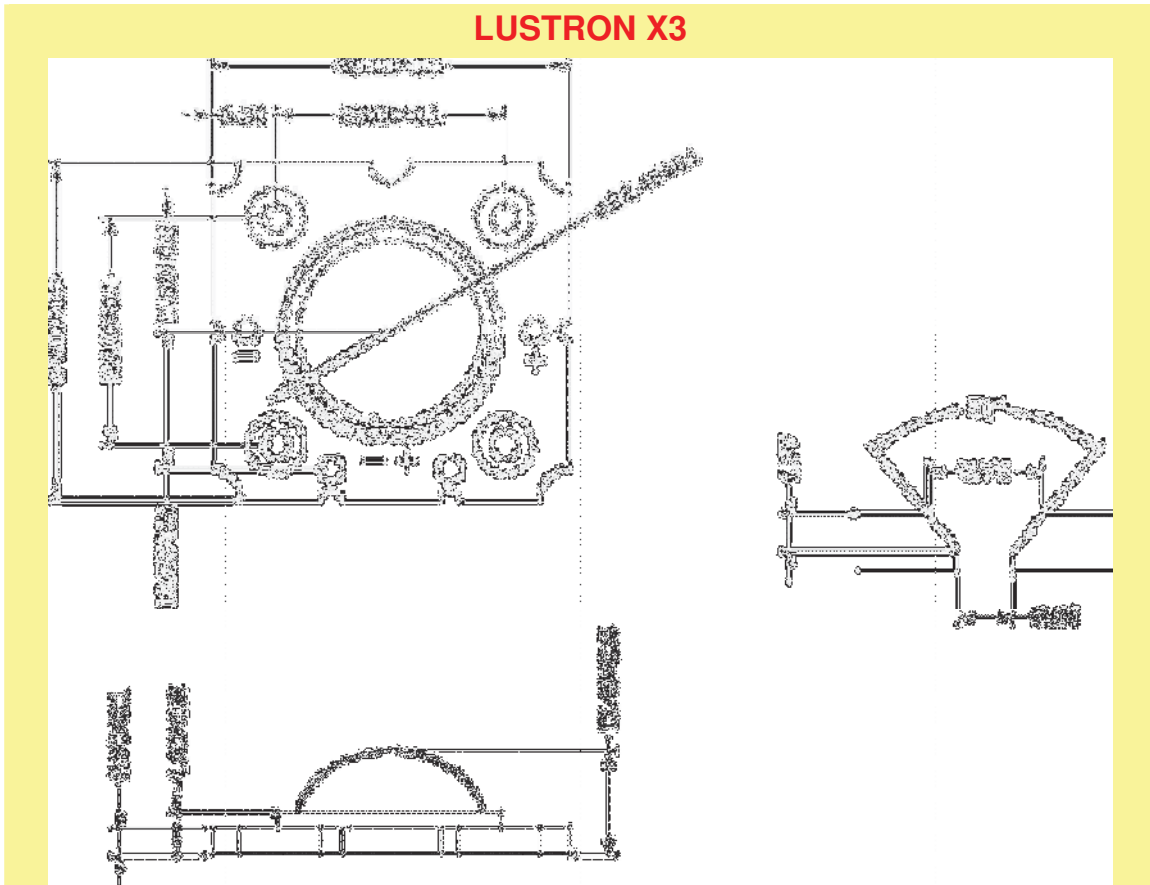

Note1: Drawing not to scale. All dimensions are in millimeters.

LUSTRON X3

LUSTROUS[®]

GREEN TECHNOLOGY OF LIGHTINGS

Flux Characteristics at 1050 mA, Junction Temperature T_j = 25 °C

Table.2

Color	Minimum Luminous Flux (lm)	Typical Luminous Flux (lm)
Warm White (3000K)	500 lm	600 lm
Neutral White (4000K)	500 lm	600 lm
Cool White (5700K)	660 lm	800 lm

Note1: Brightness is measured in total power with tolerable errors of 10%. Minimum luminous flux performance guaranteed within published operating conditions.

Note2: Higher luminous flux will become available in the near future.

Optical Characteristics

Table.3

Color	λ _d (nm) or CCT(K)			Viewing Angle (degrees)	CRI
	Min	Typ	Max		
Warm White	2500K	3000K	3100K	~120	75
Cool White	4750K	5700K	10000K	~120	75

LUSTRON X3

Electrical Characteristics

Table.4

Color	Forward Voltage (V) for 1050 mA forward current		
	Min	Typ	Max
Warm White			
Neutral White	9.4	10.5	11.5
Cool White			

Note1: Lustrous Technology allows a tolerance of each LED for voltage measurements.

Note2: Measurements are taken under each nominal forward current.

Absolute Maximum Ratings

Table.5

Parameters	For 1050 mA forward current		
	Warm White/ Neutral White/ Cool White		
DC Forward Current (mA)	1050		
Peak Pulsed Forward Current (mA)	1200		
LED Junction Temperature ($^{\circ}C$)	< 125		
ESD Sensitivity	+/- 4kV (HBM)		
Thermal Resistance ($^{\circ}C/W$)	~2.7		
Operating Temperature ($^{\circ}C$)	-25 ~ +85		
Storage Temperature ($^{\circ}C$)	-40 ~ +100		
Soldering Temperature ($^{\circ}C$)	260 (duration should be less than 5 seconds)		

Note1: Proper current operating must be observed to maintain junction temperature below the maximum.

LUSTROUS[®]
 GREEN TECHNOLOGY OF LIGHTINGS

Relative Intensity vs. Current (T_j = 25°C)

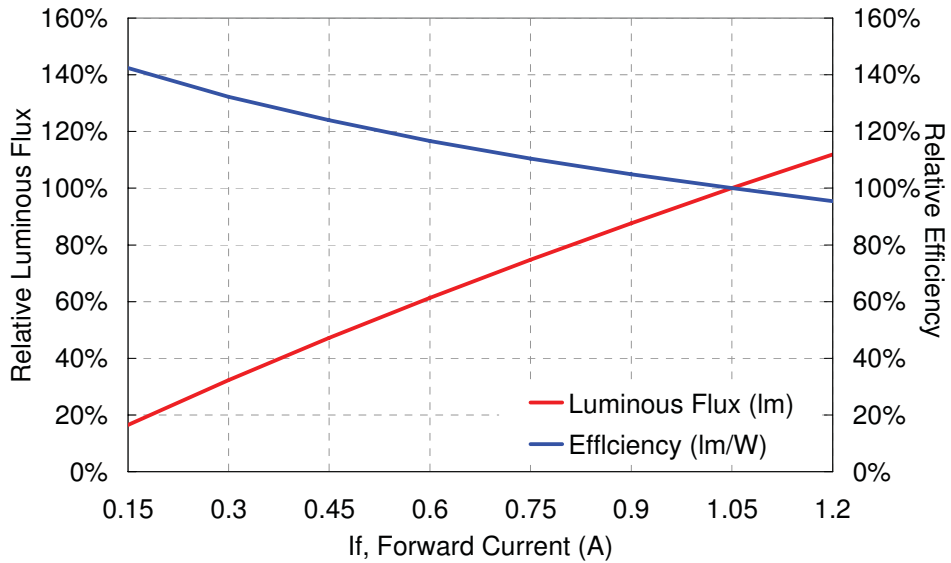

Photometric Output vs. Board Temperature (If = 600mA)

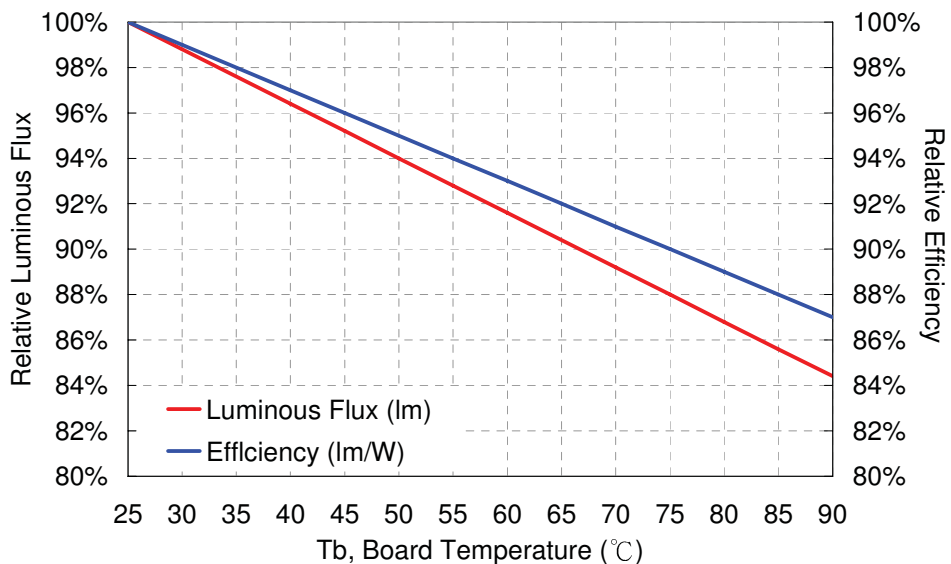

LUSTRON X3

Relative Spectral Power

Warm White (3000K)

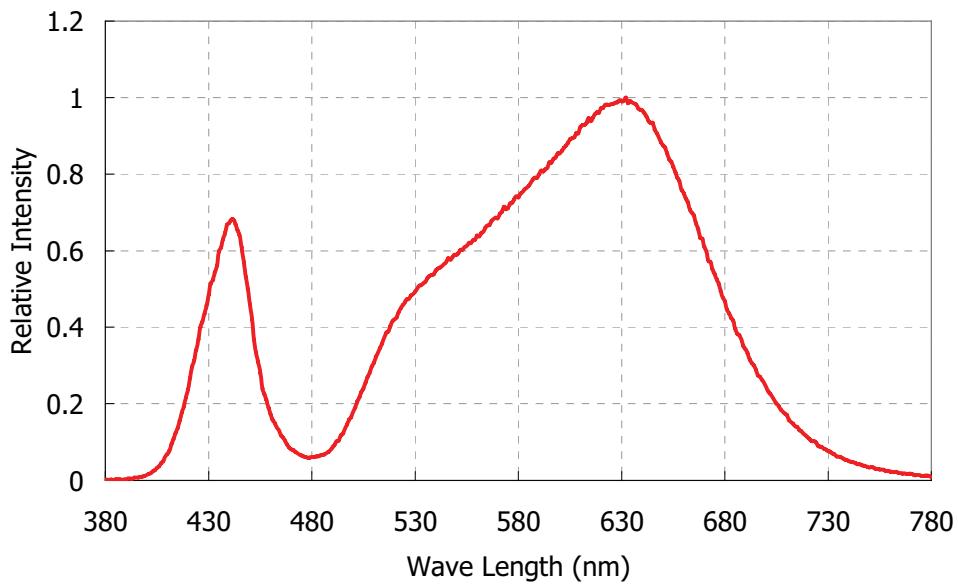

Neutral White (4000K)

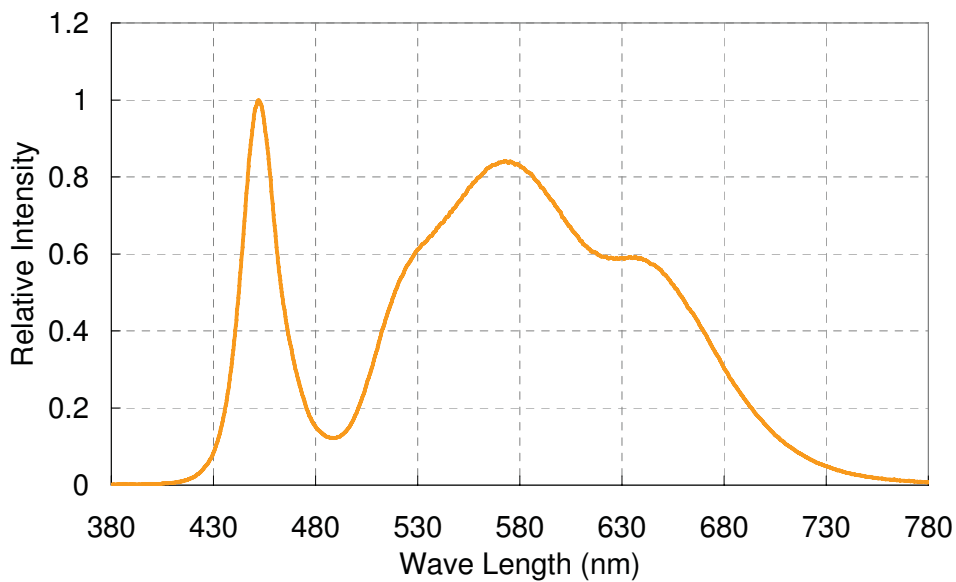

LUSTROUS[®]
GREEN TECHNOLOGY OF LIGHTINGS

Cool White (5700K)

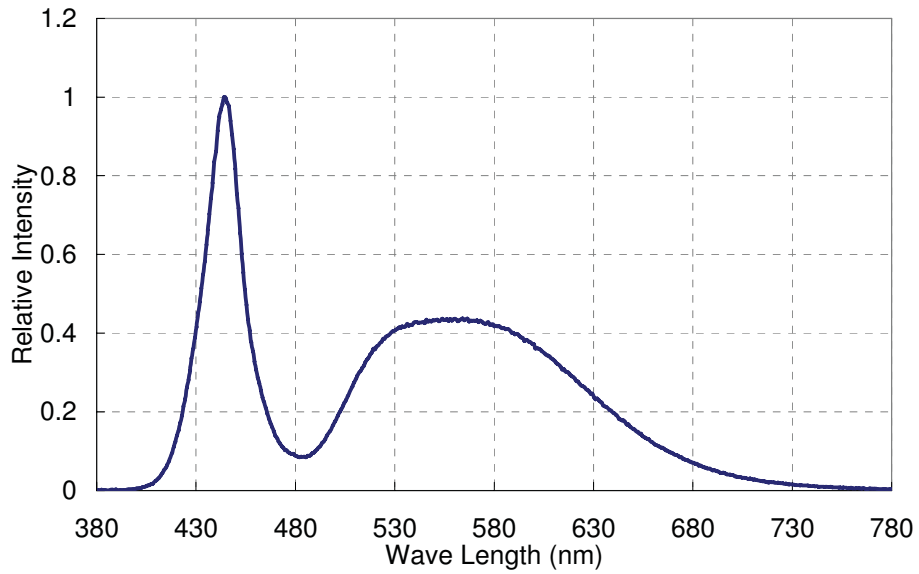

Forward Voltage vs. Current ($T_j = 25^\circ\text{C}$)

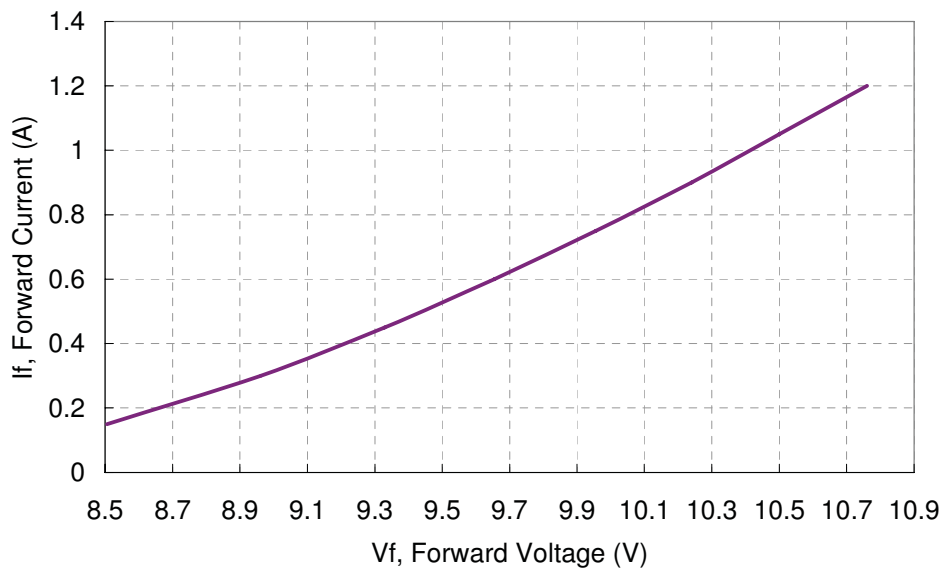

LUSTRON X3

LUSTROUS[®]

GREEN TECHNOLOGY OF LIGHTINGS

Operating Curve (Max. permissible forward current)

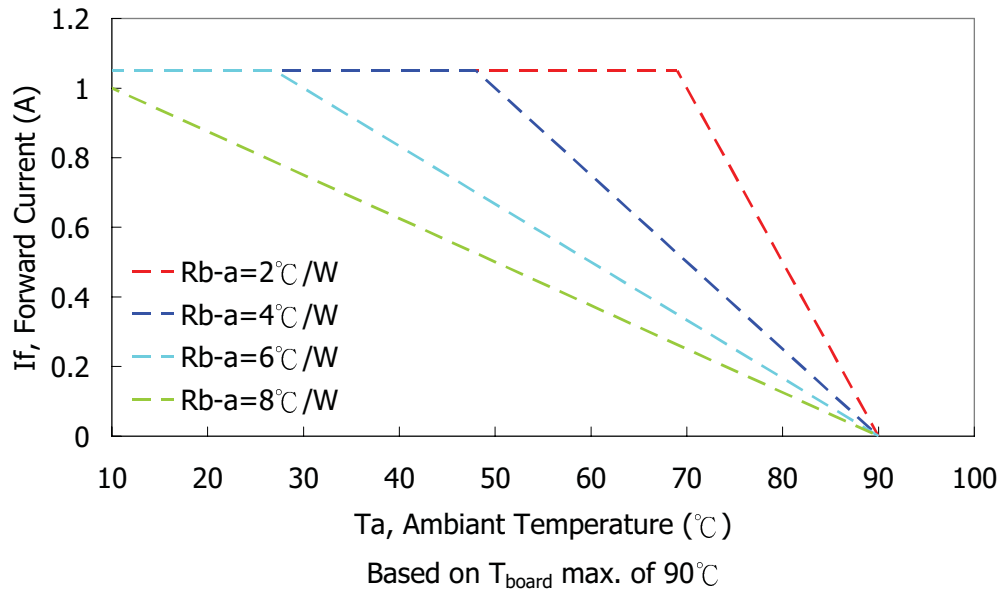

LUSTRON X3

LUSTROUS[®]

GREEN TECHNOLOGY OF LIGHTINGS

Typical Angular Beam Profile, Tj=25°C*

Pending

LUSTRON X3

LUSTROUS[®]

GREEN TECHNOLOGY OF LIGHTINGS

Product Binning

Typical manufacturing processes of LED result in a variation in performance surrounding the typical data sheet values. In order to minimize variation in the end product of application,

Lustrous bins its products for performance in brightness and chromaticity.

The tables below list the standard photometric bins for Lustrous LED (tested and binned at the indicated test current). **Product availability in a particular bin varies by product and production run. Please contact your Lustrous sales representative for further information regarding product availability.**

Brightness Binning Information *

Table.6

BIN Code	Lv (lm)	
	min.	max.
A	110	140
B	140	170
C	170	200
D	200	230
E	230	260
F	260	290
G	290	330
H	330	370
I	370	410
J	410	450

BIN Code	Lv (lm)	
	min.	max.
K	450	500
L	500	550
M	550	600
N	600	680
O	680	760
P	760	840
Q	840	920
R	920	1000
S	1000	1100
T	1100	1200

*Note1: Brightness is measured in total luminous flux with tolerable errors of 10%.Maximum.

LUSTRON X3

Chromaticity Binning Information *

Warm White

Warm White BIN Table (2500~3100K)

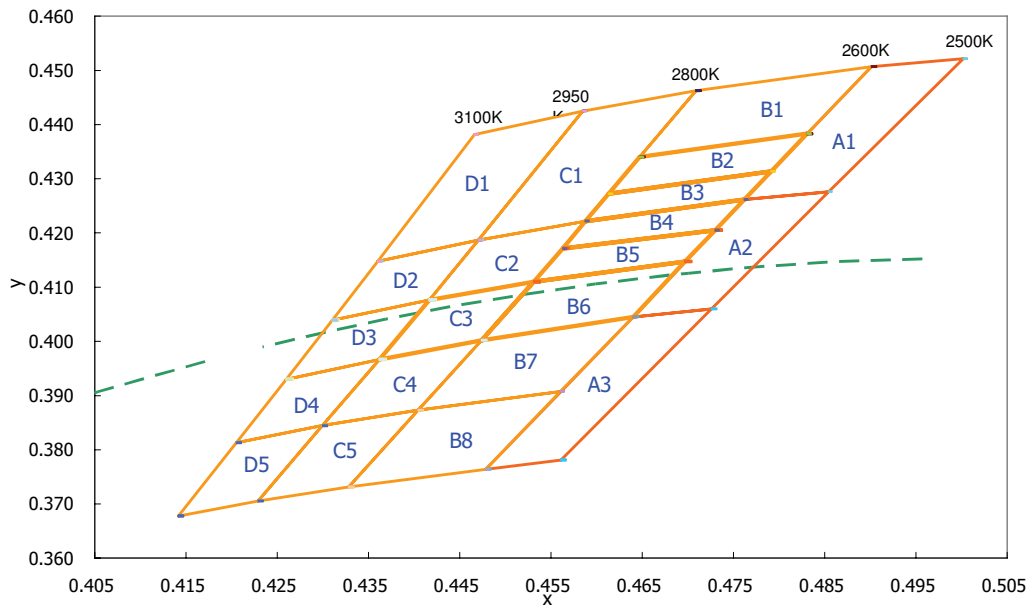

BIN Code	Chromaticity Coordinate (CIE 1931-xy)							
	x1	y1	x2	y2	x3	y3	x4	y4
A1	0.5002	0.4522	0.4901	0.4507	0.4762	0.4262	0.4854	0.4276
A2	0.4854	0.4276	0.4762	0.4262	0.4640	0.4045	0.4726	0.4060
A3	0.4726	0.4060	0.4640	0.4045	0.4478	0.3764	0.4561	0.3781
B1	0.4901	0.4507	0.4709	0.4463	0.4647	0.4340	0.4831	0.4383
B2	0.4831	0.4383	0.4647	0.4340	0.4613	0.4272	0.4791	0.4314
B3	0.4791	0.4314	0.4613	0.4272	0.4587	0.4222	0.4762	0.4262
B4	0.4762	0.4262	0.4587	0.4222	0.4563	0.4172	0.4730	0.4205
B5	0.4730	0.4205	0.4563	0.4172	0.4531	0.4110	0.4697	0.4147
B6	0.4697	0.4147	0.4531	0.4110	0.4474	0.4002	0.4640	0.4045
B7	0.4640	0.4045	0.4474	0.4002	0.4405	0.3873	0.4560	0.3908

LUSTROUS[®]

GREEN TECHNOLOGY OF LIGHTINGS

B8	0.4560	0.3908	0.4405	0.3873	0.4328	0.3731	0.4478	0.3764
C1	0.4709	0.4463	0.4585	0.4425	0.4470	0.4187	0.4587	0.4222
C2	0.4587	0.4222	0.4470	0.4187	0.4417	0.4076	0.4531	0.4110
C3	0.4531	0.4110	0.4417	0.4076	0.4362	0.3967	0.4474	0.4002
C4	0.4474	0.4002	0.4362	0.3967	0.4300	0.3845	0.4405	0.3873
C5	0.4405	0.3873	0.4300	0.3845	0.4229	0.3706	0.4328	0.3731
D1	0.4585	0.4425	0.4466	0.4382	0.4360	0.4148	0.4470	0.4187
D2	0.4470	0.4187	0.4360	0.4148	0.4311	0.4039	0.4417	0.4076
D3	0.4417	0.4076	0.4311	0.4039	0.4260	0.3930	0.4362	0.3967
D4	0.4362	0.3967	0.4260	0.3930	0.4205	0.3813	0.4300	0.3845
D5	0.4300	0.3845	0.4205	0.3813	0.4142	0.3678	0.4229	0.3706

LUSTRON X3

Cool White

Cool White Bin Table (4750~10000K)

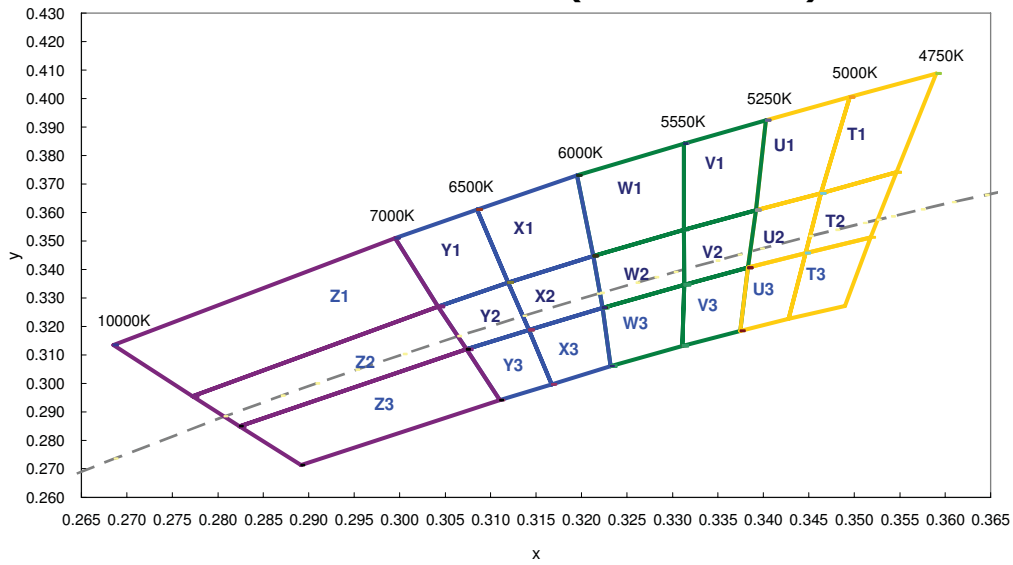

Table.9

BIN Code	Chromaticity Coordinate (CIE 1931-xy)							
	x1	y1	x2	y2	x3	y3	x4	y4
T1	0.3590	0.4088	0.3546	0.3741	0.3463	0.3667	0.3495	0.4005
T2	0.3546	0.3741	0.3518	0.3513	0.3446	0.3458	0.3463	0.3667
T3	0.3518	0.3513	0.3490	0.3272	0.3428	0.3227	0.3446	0.3458
U1	0.3495	0.4005	0.3463	0.3667	0.3392	0.3608	0.3403	0.3924
U2	0.3463	0.3667	0.3446	0.3458	0.3383	0.3406	0.3392	0.3608
U3	0.3446	0.3458	0.3428	0.3227	0.3374	0.3184	0.3383	0.3406
V1	0.3403	0.3924	0.3392	0.3608	0.3313	0.3540	0.3313	0.3841
V2	0.3392	0.3608	0.3383	0.3406	0.3313	0.3346	0.3313	0.3540
V3	0.3383	0.3406	0.3374	0.3184	0.3311	0.3132	0.3313	0.3346
W1	0.3313	0.3841	0.3312	0.3540	0.3213	0.3448	0.3195	0.3730
W2	0.3313	0.3540	0.3313	0.3346	0.3223	0.3266	0.3213	0.3448

LUSTROUS[®]

GREEN TECHNOLOGY OF LIGHTINGS

W3	0.3313	0.3346	0.3311	0.3132	0.3232	0.3061	0.3223	0.3266
X1	0.3195	0.3730	0.3213	0.3448	0.3119	0.3354	0.3085	0.3610
X2	0.3213	0.3448	0.3223	0.3266	0.3142	0.3188	0.3119	0.3354
X3	0.3223	0.3266	0.3232	0.3061	0.3167	0.2997	0.3142	0.3188
Y1	0.3085	0.3610	0.3119	0.3354	0.3042	0.3270	0.2995	0.3510
Y2	0.3119	0.3354	0.3142	0.3188	0.3073	0.3120	0.3042	0.3270
Y3	0.3142	0.3188	0.3167	0.2997	0.3110	0.2941	0.3073	0.3120
Z1	0.2995	0.3510	0.3042	0.3270	0.2772	0.2955	0.2685	0.3135
Z2	0.3042	0.3270	0.3073	0.3120	0.2824	0.2850	0.2772	0.2955
Z3	0.3073	0.3120	0.3110	0.2941	0.2892	0.2713	0.2824	0.2850

*Note1: Chromaticity is measured in Chromaticity Coordinate (CIE 1931-xy) with tolerable errors of +/-0.005.Maximum.

LUSTRON X3

Print Code Guideline

L A S 1 1 0 N W C 0 D - S R F S D

1

X X X X X X X X X X X X X X 08 34

2

3 4

V 0 - N - V 2 - X

5

6

7

8

Table.10

1 P/N	2 Internal Code	3 Year	4 Week
Warm White (3000K): LAS110CLC0D-SRFSD		08: 2008	01: Week 01
Cool White (5700K): LAS110NWC0D-SRFSD		09: 2009	02: Week 02
		10: 2010	03: Week 03

5 Vf	6 Brightness	7 Chromaticity	8 Customer Code
V0: Without Binned	See Bin Code Definition	See Bin Code Definition	

LUSTRON X3

®

LUSTROUS

GREEN TECHNOLOGY OF LIGHTINGS

Typical Packaging

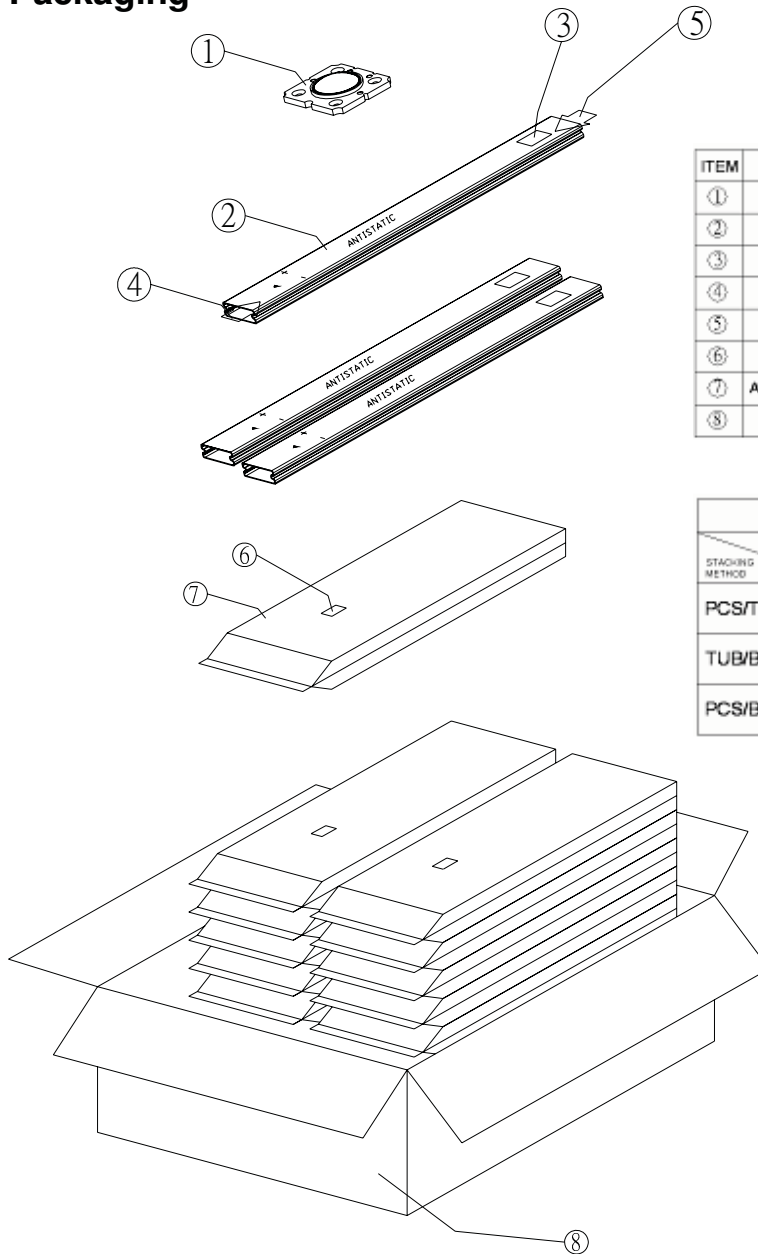

ITEM	DESCRIPTION
①	LUSTRON X3
②	PLASTIC TUBE
③	ADHESIVE MAIN LABEL
④	END-PLUG WHITE
⑤	END-PLUG BLACK
⑥	ADHESIVE MAIN LABEL
⑦	ALUMINUM MOISTURE BARRIER BAG
⑧	BOX

STACKING METHOD	
STACKING METHOD	PROD NO.
	LUSTRON X3
PCS/TUB	10
TUB/BUNDLE	2
PCS/BOX	600 (20 x 30)

LUSTRON X3

Precaution for Use

Over-current Proof

1. Customer must not drive the LEDs with reverse current and should apply resistors for extra protection.
2. When driving the products, the clamp voltage must be set at **12V** in driver.

Storage

1. Do not open the moisture barrier bag (MBB) before the products are ready to be used.
2. Storage Condition (before opening the MBB):
 - Storage Temperature: -40~80 °C
 - Relative Humidity < 90% RH
 - Please re-seal the MBB when storing longer than 3 weeks.
 - The products should be used within half of a year.
3. Storage Condition (after opening the MBB):
 - Storage Temperature: -40~80 °C
 - Relative Humidity < 90% RH
 - The products should be used (assembled) as soon as possible after opening the MBB.

Handling

1. Do not touch the lighting area during handling and assembling.